



RESEARCH ARTICLE

# Ecological factors and morphological traits of *Coffea Liberia* Hiern in Kalipuro District, Banyuwangi Regency

Naila Izzatul Mukhoyyaroh, Rodiyati Azrianingsih & Luchman Hakim\*

Department of Biology, University of Brawijaya, Malang 65145, Indonesia.

\*Email: [luchman@ub.ac.id](mailto:luchman@ub.ac.id)



## ARTICLE HISTORY

Received: 08 September 2023

Accepted: 07 March 2024

Available online

Version 1.0 : 25 April 2024



## Additional information

**Peer review:** Publisher thanks Sectional Editor and the other anonymous reviewers for their contribution to the peer review of this work.

**Reprints & permissions information** is available at [https://horizonepublishing.com/journals/index.php/PST/open\\_access\\_policy](https://horizonepublishing.com/journals/index.php/PST/open_access_policy)

**Publisher's Note:** Horizon e-Publishing Group remains neutral with regard to jurisdictional claims in published maps and institutional affiliations.

**Indexing:** Plant Science Today, published by Horizon e-Publishing Group, is covered by Scopus, Web of Science, BIOSIS Previews, Clarivate Analytics, NAAS, UGC Care, etc See [https://horizonepublishing.com/journals/index.php/PST/indexing\\_abstracting](https://horizonepublishing.com/journals/index.php/PST/indexing_abstracting)

**Copyright:** © The Author(s). This is an open-access article distributed under the terms of the Creative Commons Attribution License, which permits unrestricted use, distribution and reproduction in any medium, provided the original author and source are credited (<https://creativecommons.org/licenses/by/4.0/>)

## CITE THIS ARTICLE

Mukhoyyaroh NI, Azrianingsih R, Hakim L. Ecological factors and morphological traits of *Coffea Liberia* Hiern in Kalipuro District, Banyuwangi Regency. Plant Science Today (Early Access). <https://doi.org/10.14719/pst.2939>

## Abstract

This study aimed to analyze the ecological factors and morphological traits of Liberica coffee in Kalipuro District, Banyuwangi Regency. Ecological and morphological factors were measured, and observations were recorded accordingly. The observation of significant morphological characters has been thoroughly conducted. The observed ecological factors were microclimate factors, including altitude, air temperature, humidity, light intensity, rainfall rate, soil pH, soil temperature, and soil moisture. The Paleontological Statistics (PAST) program was used to perform multivariate analysis to group liberica coffee variants based on morphological traits and physical factors of the plantation. The study found that physical environmental factors had a relatively significant influence on morphological variation in each population. The light intensity and relative humidity were the physical environmental factors related to morphological traits, such as leaf shape index, number of flowers per inflorescence, and leaf surface index based on principal component analysis (PCA). Unstable weather conditions can influence environmental factors, which, in turn, can profoundly impact morphological characteristics, specifically the flowering season. The study revealed a statistically significant correlation between light intensity and the number of flowers per inflorescence.

## Keywords

association; coffee; environment; liberica; morphological trait

## Introduction

Liberica coffee, scientifically known as *Coffea Liberia* Hiern, is a distinct coffee variety with numerous variants that can be quite similar. This similarity poses a challenge in accurately classifying the different taxonomic positions. Despite decades of research on the various infra-species cases of liberica coffee, distinguishing between the different variants remains challenging, as their morphological features are highly variable. Liberica coffee belongs to the Rubiaceae family species from Africa (1, 2), and it was first introduced in Indonesia during the Dutch colonial era. *Coffea liberica* is one of the main plantations in the agroforestry system maintained by smallholders in Banyuwangi (3). The long-term introduction period of Liberica coffee may have led to morphological variations in response to environmental factors. Liberica coffee can grow in various conditions, including peatlands and humid environments, and is resistant to pests and diseases. Coffee plants in

open fields exhibit less optimal growth than those in shaded orchards. To mitigate the effects of direct sunlight on the coffee plant (4), adding shade plants is essential. Liberica coffee, with a relatively larger land cover compared to arabica coffee (*Coffea arabica*) and robusta coffee (*Coffea canephora*), has a relatively higher carbon stock potential. The average carbon emission from liberica coffee plants reaches 23.7 mg CO<sub>2</sub>/Ha/year (5).

The *Coffea liberica* plant species encounter issues with its infraspecific taxa, which require clarification due to significant variation and morphological inconsistencies (6). This challenge is attributed to the impact of the environment on the plant growth process. Environmental factors can cause temporary or permanent changes to the physical characteristics of coffee plants. Such changes may cause morphological variations that could lead to speciation or long-term variation. As a result, this research looks at the environmental factors and physical features of coffee agroforestry plantations in Kalipuro District, Banyuwangi Regency.

## Materials and Methods

### Study area

This study was conducted from August to November 2022 in coffee-based agroforestry belonging to smallholders in Kalipuro District, Banyuwangi Regency, East Java, Indonesia (Fig. 1). Kalipuro District covers an area of 310.03 km<sup>2</sup>, with 4,397 Ha used for coffee plantation (7). Banyuwangi is well-known for its diverse types of shade trees in its agroforestry system, and coffee is the main plantation in this area (8).

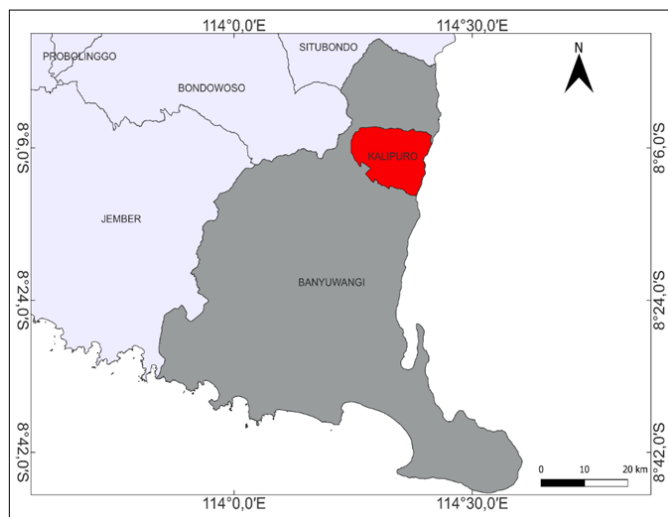

Fig. 1. Research area map (red filled).

### Data Collection

Observations were made in the measurement of ecological and morphological factors. Observations of significant morphological characters have been explored (unpublished project). A total of 20 liberica coffee accessions were observed from 9 liberica coffee plantations in Kalipuro District. Twenty accessions were grouped based on architecture and labeled as A, B, C and D accessions based on branching type. "A" group represents a drooping branch

with a turning upward tip. The "B" group represents the horizontal branch. The "C" Group represents the drooping branch (declinate), while the "D" group represents the leaning up branch (patents). Ecological factors observed were microclimate factors, including altitude, air temperature, humidity, light intensity, rainfall rate, soil pH, soil temperature, and soil moisture. Microclimate factors at each Liberica coffee plantation location were measured and subsequently compared between Liberica coffee plantation locations. The elevation was measured using an essential GPS; the temperature was measured using a thermometer; the humidity was measured using a psychrometer; and light intensity was measured using a lux meter. According to the local station, the monthly average of temperature, relative humidity, and rainfall rate information was obtained from the Meteorological, Climatological, and Geophysical Agency (BMKG) data. Soil temperature was measured using a digital thermometer, and soil moisture and pH were measured using a soil moisture and pH meter.

Several morphological traits were significantly observed in the previous study (1). The quantitative and qualitative characteristics are based on the Descriptor for Coffee (*Coffea* spp. and *Psilanthus* spp.) by IPGRI. Meanwhile, only leaf length (LL), leaf width (LW), and number of flowers per inflorescence represent reliable variables during the multivariate analysis. Leaf surface index (LL x LW) and leaf shape index (LL/LW) were calculated from leaf length and leaf width ratio (1). Leaf measurements were taken on an average of 5 mature leaves, observed on those more than three nodes from the terminal bud, and measured from petiole to leaf apex. The number of flowers per inflorescence was calculated as the average of 10 axils, randomly selected from different nodes. The assessment method used refers to the Descriptor for Coffee (*Coffea* spp. and *Psilanthus* spp.) by the International Plant Genetic Resources Institute (IPGRI) (9).

### Data Analysis

Data analysis was conducted to determine the effect of the environment on the morphological characteristics of liberica coffee in different populations. Multivariate principal component analysis (PCA) biplot and cluster analysis were performed using the Paleontological Statistics (PAST) program to determine the grouping of liberica coffee variants based on morphological characters and physical environmental factors of liberica coffee plantations. Additionally, correlation analysis using the Pearson correlation coefficient (Eqn. 1) was obtained to measure the strength of the linear relationship between environmental factors of liberica coffee plantations and the morphological characteristics of liberica coffee accessions.

$$r_{XY} = \frac{\sum_{i=1}^n (x_i - \bar{x})(y_i - \bar{y})}{\sqrt{\sum_{i=1}^n (x_i - \bar{x})^2 \sum_{i=1}^n (y_i - \bar{y})^2}} \quad \dots\dots\dots(1)$$

Where  $x_i$  and  $y_i$  are the samples, while  $\bar{x}$  and  $\bar{y}$  are the means of  $x_i$  and  $y_i$ , respectively. The  $r$  value ranges from +1 to -1, where +1 indicates a positive correlation, 0 means no correlation, and -1 indicates a negative correlation (10).

## Results and discussion

### Ecological Factors of Liberica Coffee Plantations in Kalipuro District

Several coffee agroforestry plantations in Kalipuro District use Liberica and robusta coffee as main crops (Fig. 2). The coffee agroforestry system in Kalipuro District utilized food crops as a multi-cropping on the land. The crops frequently planted in this agroforestry area are coconut, banana,



Fig. 2. Coffee-based agroforestry in Kalipuro District.

multi-level crops to improve land use (11, 12). Coffee plants often used as main plantations by smallholder farmers are robusta and liberica coffee. Farmers prefer *Robusta* coffee because of its resistance to leaf rust disease, relatively easy maintenance, and higher production (13). Meanwhile, Liberica coffee has been cultivated due to the potential for solid bark utilization commonly used in grafting methods with other types of coffee, i.e., robusta coffee. This utilization allows coffee grafting individuals to survive during dry periods because of liberica coffee's strong bark, adaptability to unfavorably environmental conditions, and more resistance to leaf rust disease than robusta coffee (14).

The physical environmental conditions of liberica coffee plantations consist of Bulusari 1 (B3 and B4), Bulusari 2 (D1 and D2), Gombengsari 1 (A1, B5, C1, C2, and C3), Gombengsari 2 (C4 and C5), Gombengsari 3 (A2 and B2), Papring 1 (A3), Papring 2 (A5), Secang (A4), and Telemung (B1, D3, D4, and D5) population in Kalipuro District did not show much difference since the observed plantations are still in the same region. The number in the population name indicated the different plantations of Liberica coffee. Liberica coffee plantations in Kalipuro District are distributed 100-500 m above sea level. The altitude of coffee-based agroforestry plantations indirectly affects seasonal microclimate change because of the canopy from the shading plant. Shade also modifies environmental conditions such as coffee physiology, productivity, water, and soil (15). Based on the physical environmental parameters of liberica coffee plantations, it is known that the soil temperature does not vary between populations. However, there are soil moisture variations in liberica coffee plantation areas (Fig. 3). Soil moisture ranges from 1% to 10%, with the lowest soil moisture found in the A3 accession plantation area. In contrast, the highest soil moisture was found in the A4 plantation area. Both accessions are located in the same area, namely the Papring population. However, they come from different farmland.

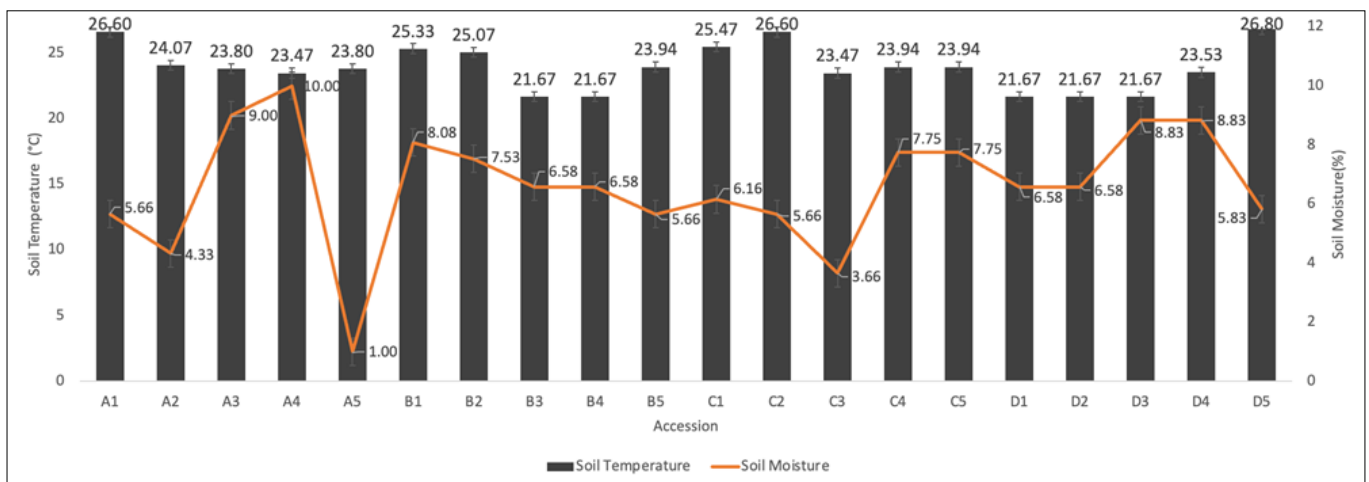

Fig. 3. Temperature (°C) and soil moisture (%) parameters of liberica coffee plantations in Kalipuro District.

porang (*Amorphophallus* sp.), durian, legumes, and coffee with a random mixture planting pattern. The agroforestry system in the tropics and subtropics has been applied since the 1980s, and it was inventoried by ICRAF, using

The differences occurred due to weather conditions at the moment of data collection. The weather conditions at the data collection were sunny, and in the few days before data collection, there were no rain occurrences, so the soil conditions turned out to be quite dry. Soil pH levels at



the location of liberica coffee plantations in Kalipuro District ranged from 6.67 to 7.8 (Fig. 4), with the lowest pH in the B1 coffee accession plantation area. In contrast, the

with low photosynthetic efficiency due to photorespiration. So coffee plants need shades to optimize plant growth. Concerning shade plants, light intensity correlates

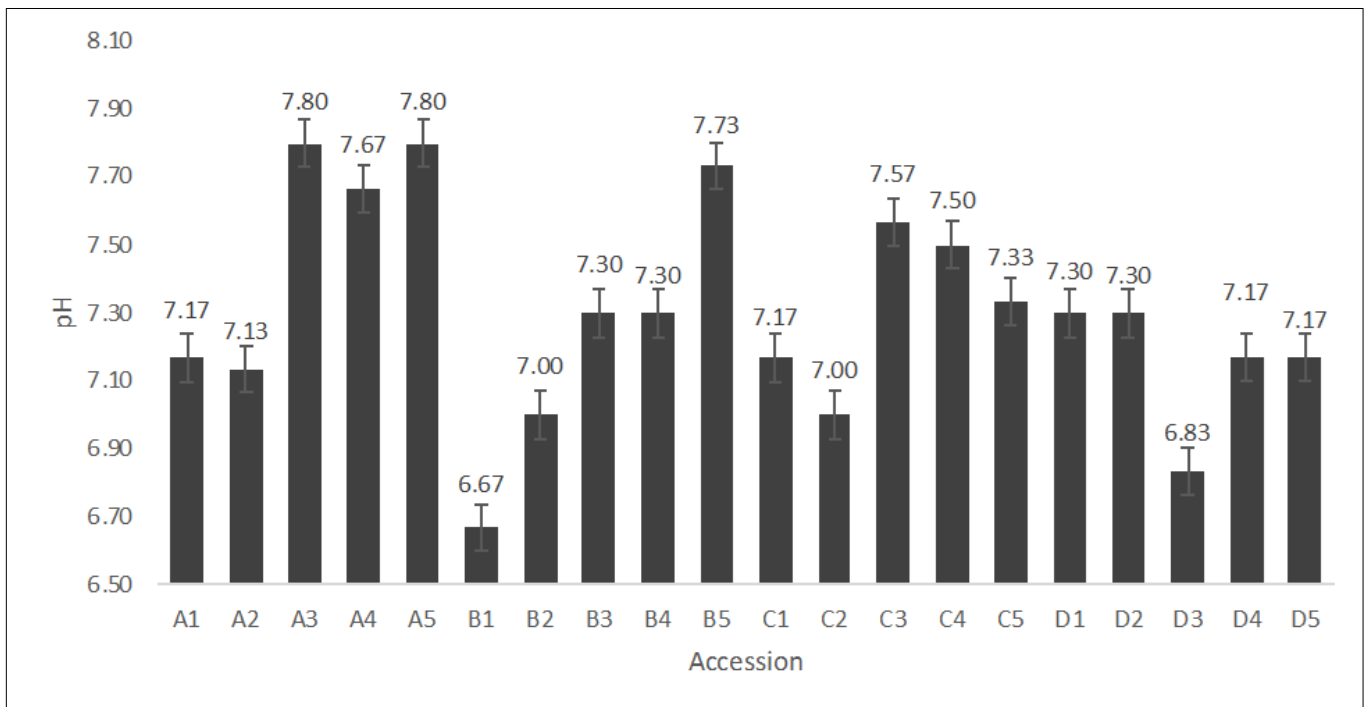

Fig. 4. Soil pH parameter of liberica coffee plantations in Kalipuro District.

highest pH was found in the A3 and A5 accession plantations. The suitability level of pH for coffee land is specified based on four levels, including highly suitable (5.5-6), suitable (6.1-7.0), marginally suitable (7.1-8.0), and unsuitable (>8) (16). According to these guidelines, soil pH in the liberica coffee plantations in Kalipuro District is considered to be at suitable to a marginally suitable level. However, other physical environmental parameters, such as light intensity, were known to have variations. The light intensity of the liberica coffee plantations was recorded, ranging from 100-1400 lux (Fig. 5). The interaction between light intensity and coffee plants affects their successful coffee growth and production. Coffee plants represent C3 plants

with the level of shade on the plant and thus indirectly affects stomatal conductance and photosynthetic rate (17). Shade plants are sensitive to reduced light and significantly affect root, leaf, and shoot growth parameters that are inadequate to adequate light intensities (18).

Light intensity and solar irradiance duration are correlated with the relative humidity of the liberica coffee plantation site. The relative humidity of Liberica coffee plantation sites in the Kalipuro District ranges from 84 to 100 percent (Fig. 5), with the highest relative humidity of Liberica coffee plantation sites reaching 100% or almost 100%. The lowest relative humidity was found in the accession A2 plantation site. Relative humidity in the Liberica

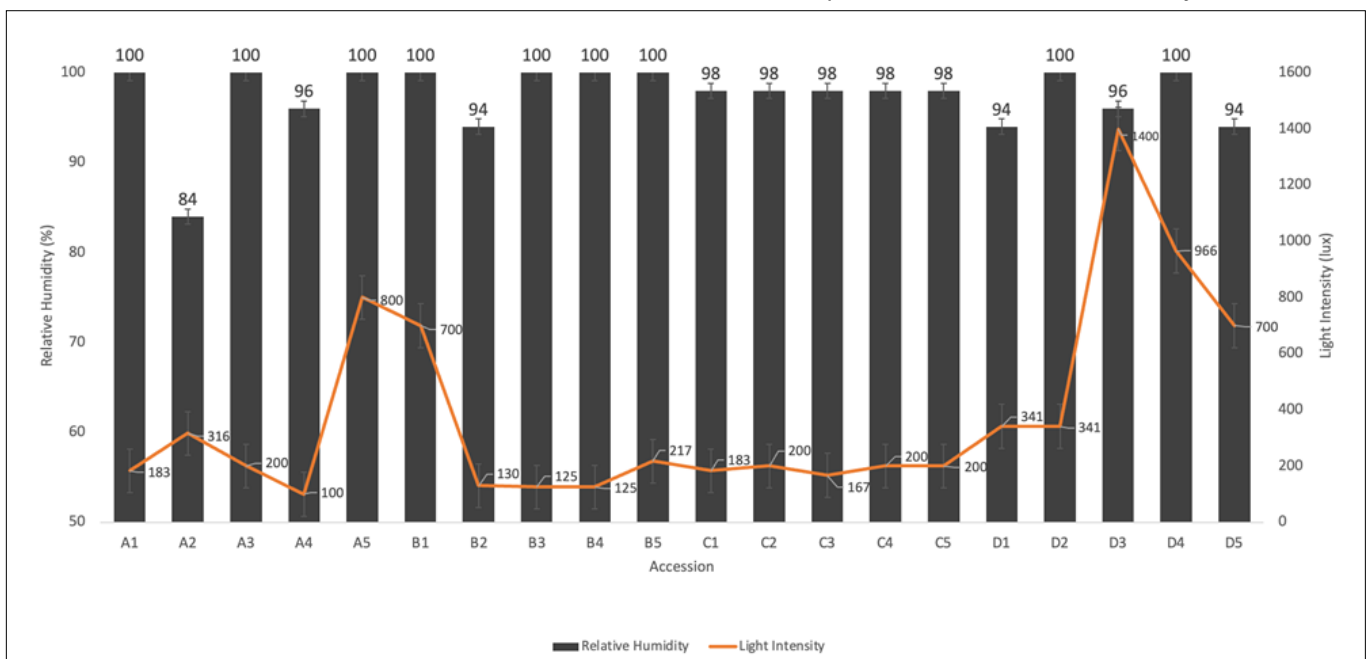

Fig. 5. Relative humidity (%) and light intensity (lux) parameters of liberica coffee plantations in Kalipuro District.

plantation site is almost the same. Here the cause of the average temperature in the plantation site is relatively similar, and there is no wide variation. The relative humidity is related to the amount of moisture in the air depending on the ratio of the water vapor fraction in the mixture to the water vapor fraction in the saturated mixture at the same temperature and pressure. It was analyzed based on the wet and dry air temperatures - the smaller the gap between dry and wet bulb temperature, the greater the relative humidity. The wet-bulb temperature depends on the moisture content in the air in conjunction with the dry-bulb temperature to determine the humidity (19). Air temperature and humidity have a strong relationship and inverse trend. An increased trend in the air temperature leads to a decreasing trend in relative humidity. The association between variables is valid for the other way round (20). The increasing relative humidity also positively correlated with the increasing rate of photosynthesis because as the relative humidity increases, stress to the water content on the leaf surface decreases and triggers an increasing stomatal conductance so that the CO<sub>2</sub> concentration in the leaves is also high (21).

According to the secondary data information acquired from the Indonesian Meteorology, Climatology, and Geophysics Agency (BMKG), it was found that the average air temperature and relative humidity of the liberica coffee plantation sites did not vary during the data collection period from August to November (Fig. 6). The air temperature average ranged from 26.49°C to 27.26°C. The relative humidity values of the liberica coffee plantation sites ranged from 77.83% to 82.97%, with the highest relative humidity occurring in October and the lowest relative humidity occurring in August. There were variations in rainfall rate during the sampling period of liberica coffee. The highest rainfall occurred in October, while the lowest was

in August. Environmental conditions with high rainfall on coffee plantations can negatively affect the coffee plants. Rainfall may indirectly affect coffee yields. The high rainfall rate can affect plants by damaging and disrupting the flowering process. Heavy rainfall might cause coffee flowers to fall off, so the growth of the coffee cherries is a failure. Previous research states that the wet period significantly affects the growth of coffee cherries and beans, but the excessive rain intensity may negatively impact the flowering coffee plants. Rain that occurred for 4-5 consecutive days during the flowering period could lead to fruiting failure (22).

#### **Correlation of Morphological Trait and Ecological Factors in Liberica Coffee Plantation**

The morphological variation of Liberica coffee varieties is correlated with the physical environmental conditions of liberica coffee plantations, as indicated by the leaf shape index, relative humidity, number of flowers per inflorescence, light intensity, and leaf surface index. These variables are correlated after a multivariate analysis has been generated. From 20 accessions in 9 plantations, the liberica coffee leaf shape index ranged from 1.69 to 2.49, with the highest leaf shape index belonging to the D1 accession at Bulusari 2 plantation, while the lowest shape index belonging to C3 and A5 accession at Gombengsari 1 and Papring 2 plantations, respectively. At the same time, the leaf area index ranged from 313.79 cm<sup>2</sup> to 721.00 cm<sup>2</sup>, with the lowest value attributed to C4 accession at the Gombengsari 2 plantation. In contrast, the highest value was recorded for B3 accession at Bulusari 1 Plantation. The environmental conditions, including light intensity and temperature, can be the growth factors. A previous study declared that along with the increase in light intensity, mesophyll cell surface area, volume per leaf surface area, leaf thickness, and density increased (23). However,

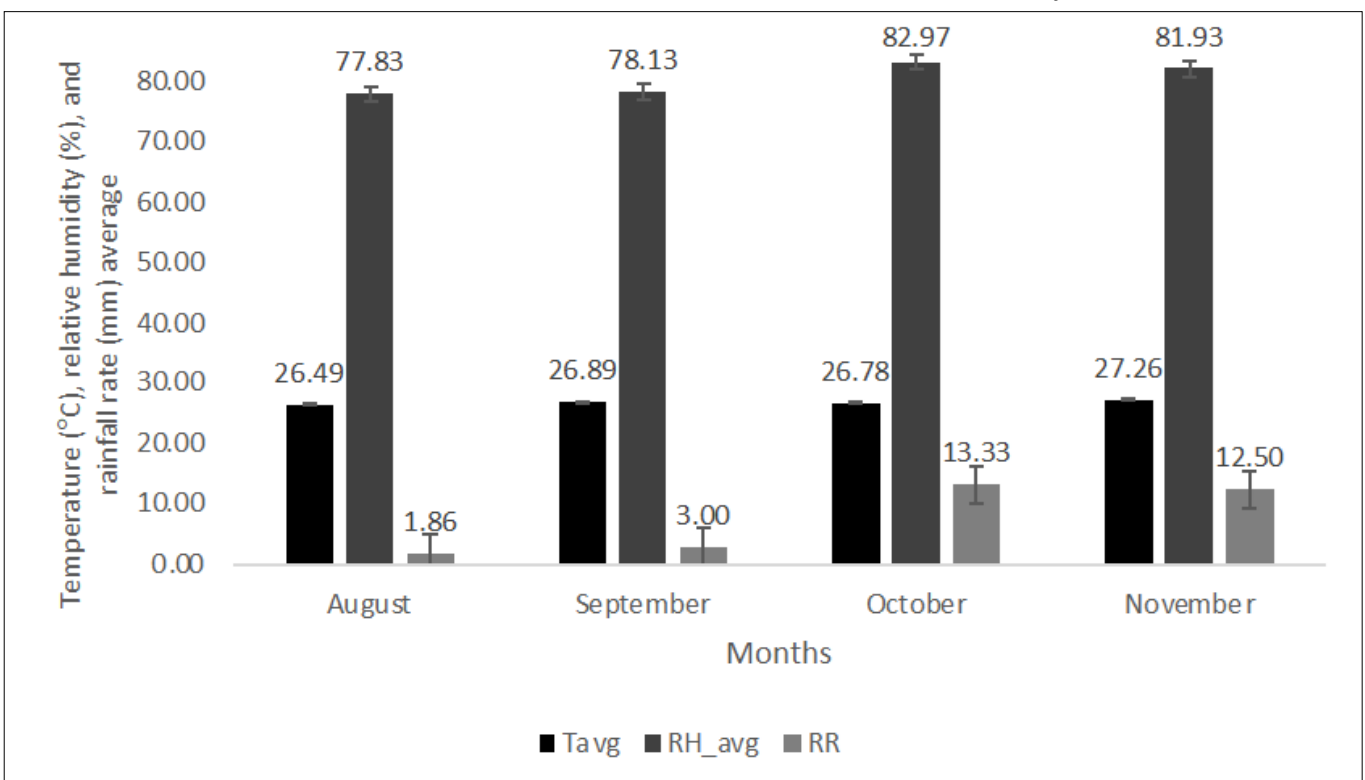

**Fig. 6.** Monthly average of temperature (°C), relative humidity (%), and rainfall rate (mm) of liberica coffee plantations in Kalipuro District.

cell number and size are leading factors that determine leaf size under the coordination of both factors and correlate to sunlight conditions (24). Another important morphological variable in this study was the number of flowers per inflorescence. The number of flowers per inflorescence of liberica coffee varied from 0 to 26 flowers per inflorescence. Null data found in several accessions at different plantations was due to heavy rain and wind, which caused the flowers on the accessions to fall off entirely. During the flowering stage, flower bud atrophy is commonly caused by a drastic change in temperature or a sudden relief of water stress, such as the first rain in the rainy season. Although water is essential in this stage, heavy rainfall may cause an episode of acute flower atrophy (25).

The environmental conditions of the plantation area are predicted to have influenced some morphological characters. Among these variables, it is known that the correlation between significant variables only exists between light intensity and the number of flowers per inflorescence, which has a correlation value of 0.52 ( $p < 0.05$ ). In contrast, the other variables have a correlation value of less than 0.5 with a significance value greater than 0.05 (Table 1). From this correlation of light intensity and the number of flowers per inflorescence, a positive correlation data shown in Table 1 was obtained. The correlation between the data is optimized by selecting the principal components (PCs). PC reduction is implemented to provide the best data summary by geometrically reducing the data to lower dimensions (26).

The principal component analysis (PCA) and biplot of the morphological traits and physical environmental factors (Fig. 7) of the liberica coffee plantation in the Kalipuro District revealed that the relevant variables have 57.43% of the total percentage as shown in Table 2, which is cumulative of two first reliable PC (PC 1 and PC 2). Per-

cent variance refers to multivariate variance analysis or total variability generated by the model. The model generated 57.43%, indicating the total percent of variance

**Table 1.** Leaf and flower morphological trait.

Plantation	Accession	Leaf Shape Index	Leaf Area Index (cm <sup>2</sup> )	Number of Flower per Inflorescence
Bulusari 1	B3	2.12	721.00	16.20
Bulusari 1	B4	2.24	451.17	0.00
Bulusari 2	D1	2.49	348.67	0.00
Bulusari 2	D2	2.05	482.59	13.60
Gombengsari 1	A1	2.05	615.79	16.00
Gombengsari 1	B5	2.07	485.69	20.80
Gombengsari 1	C1	1.88	480.39	22.60
Gombengsari 1	C2	2.01	432.13	15.20
Gombengsari 1	C3	1.69	570.85	16.60
Gombengsari 2	C4	2.15	313.79	9.20
Gombengsari 2	C5	2.23	587.66	9.80
Gombengsari 3	A2	1.79	625.65	13.60
Gombengsari 3	B2	2.20	543.13	0.00
Papring 1	A3	2.45	568.16	13.80
Papring 2	A5	1.69	569.66	10.60
Secang	A4	1.87	467.84	8.60
Telemung	B1	1.95	612.80	17.60
Telemung	D3	2.28	606.47	26.00
Telemung	D4	2.07	592.62	19.60
Telemung	D5	1.90	479.67	20.40
<b>Average</b>		2.05	527.79	13.51

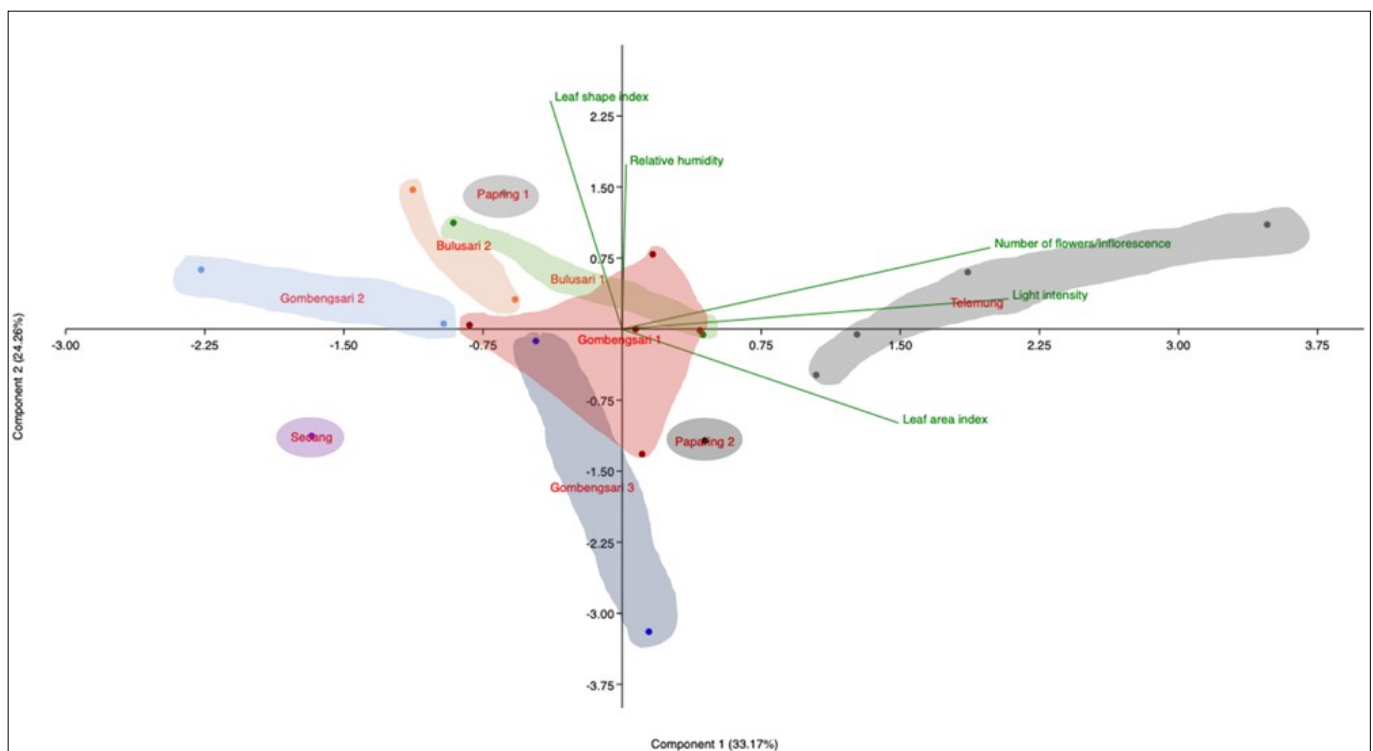

**Fig. 7.** Principal component analysis (PCA) of morphological traits and environmental factors of liberica coffee plantation.

**Table 2.** Correlation of morphological characters and physical environmental factors.

	Leaf surface index	Leaf shape index	Number of flowers per inflorescence	Light intensity	Relative humidity
Leaf surface index		0.39	0.39	0.30	0.94
Leaf shape index	-0.20		0.76	0.86	0.52
Number of flowers per inflorescence	0.22	0.08		0.03	0.90
Light intensity	0.24	-0.04	0.52*		0.97
Relative humidity	0.02	0.15	0.03	-0.01	

Note:  correlation value,  significant value (*p*)

described by factors used in the component analysis. Therefore, other variables outside the model could describe the remaining percentage. PCA is widely used to analyze data distribution based on matrix correlation or covariance. The cumulative percent variance in PCs should have at least 70% variability, but in practice, the total percentage of variance is possibly lower than that (27). Despite the relatively low percentage, the first two eigenvalues accurately represent the entire data. Experience has repeatedly shown that the top two eigenvalues represent most of the influence or variance contained in the data (28). Furthermore, the results of the PCA indicate low variation and high similarity between factors. By reducing the variables, PCA retains the primary information contained in the original data. The principal components can be determined based on eigenvalue > 1, the eigenvector representing a dataset's data distribution, the cumulative percent of the variance, and the scatter plot (29, 30). The maximum total of eigenvalue is two from the first two PCs. (Table.3.) Eigenvalues indicate the relative importance of the corresponding eigenvectors. Meanwhile, eigenvectors indicate the variance's magnitude and direction, arranged according to the respective eigenvalues, from the largest to the smallest (28).

**Table 3.** PCA eigenvalue and percent of variance.

PC	Eigenvalue	% Variance
1	1,66	33,17
2	1,21	24,26
3	0,95	19,08
4	0,69	13,70
5	0,49	9,78

The short length of the biplot's green line in PCA indicates spatial variation. The shorter the arrow, the smaller the spatial variation. Biplot is one of the most informative graphical representations in a multivariate dataset, with arrows representing the variable marker (27). Based on this data, the most negligible variation is shown by relative humidity. Biplot analysis showed that liberica coffee plants distributed in the right quadrant are distinctive from liberica coffee plants distributed in the left quadrant (Fig. 7), which is reflected by the negative correlation of the variables. Branching types of liberica coffee plants labeled alphabetically from A to D did not affect the mor-

phological variation nor the physical environment of the liberica coffee plantation location. All branching types are dispersed based on principal component analysis. The influence of the physical environment of the liberica coffee plantation in Kalipuro District showed that several populations overlap due to physical environmental factors and the morphology of liberica coffee. Principal component analysis showed that liberica coffee from Telemung plantation was characterized by a high number of flowers per inflorescence, light intensity, and leaf surface index, which contrasts with the liberica coffee plantation population in Secang, which is known to be negatively correlated with these two variables as well as other variables. The Liberica coffee population in the Gombengsari 1 plantation is characterized by relatively low levels of all morphological variables and physical environmental factors indicated by the position of coffee plants in the Gombengsari 1 plantation, which is in the center of the quadrant. The closer to the center of the quadrant, the smaller the variable values.

Liberica coffee plants in the left quadrant were characterized by low levels of all variables, except for those in Papring 1, Bulusari 1, and Bulusari 2 plantations, characterized by higher leaf shape index and relative humidity. However, some liberica coffee plants in Bulusari 1 and Bulusari 2 plantations were characterized by low levels of all observed variables. Meanwhile, coffee plants in Gombengsari 3 and Papring 2 plantations were negatively correlated with relative humidity and leaf shape index. The smaller the angle between variables, the more positively correlated they are. The larger the angle formed between the two variables, the more the correlation between the two variables becomes negative. A positive correlation was formed between the leaf shape index and the microclimate factor of relative humidity. In conditions with high humidity, the leaves do not require water efficiency mechanisms as in high light intensity conditions, which makes the leaves maintain the water content by adapting to the smaller leaf shape to reduce evaporation. The variable number of flowers per inflorescence positively correlates with light intensity and altitude. One of the factors for successful flowering is sunlight; under these conditions, flowers can bloom sufficiently, and the possibility of flower failure becomes small. In conditions with low irradiation accompanied by heavy rains, it can interfere with the flower blooming and cause shedding. Under low precipitation, rainfall could affect flowering and fruit sets as well as pho-

tosynthesis disruption. High-intensity rainfall will cause flower-dropping during the blossom period (31)

The microclimatic factors that affect the growth and morphology of Liberica coffee plants in Kalipuro District could be related to the location's altitude, which ranges from 100 to 500 masl, which indirectly impacts the physical environment of the Liberica coffee plantation. Light intensity and relative humidity are two environmental factors that positively correlate with the plants' morphological characteristics. The intensity and duration of light exposure can affect the physiology of coffee plants. Besides the microclimate factors, internal factors can influence the growth and morphological characteristics of the plants (32). Additionally, shade plants around coffee plants can impact the surrounding microclimate. High shade density can decrease the light intensity received by coffee plants, resulting in high relative humidity, while low shade density can increase light intensity and decrease relative humidity.

### *Coffea liberica* Clustering Based on morphological traits and physical environmental factors of liberica coffee plantation

The study conducted a cluster analysis to group liberica coffee variants based on their physical environmental conditions and morphological characters. The analysis revealed that at a distance of 100, there were 12 clusters, with only two large clusters and the rest being small clusters consisting of 1 accession (Fig. 8). The accessions A4 [16], B4 [2], B5 [6], C1 [7], and C2 [8] formed one cluster, while accessions A3 [15], C5 [11], C3 [9], A1 [5], and B2 [13] clustered in another. The remaining accessions formed their clusters. At a more considerable distance of 200, the grouping was divided into 6 clusters. Cluster 1 consisted of only D3 [18] accessions, while the next cluster included accessions A5 [14], B1 [17], and D5 [20]. The majority of Liberica coffee accessions clustered in one large cluster consisting of accessions D2 [4], A2 [12], A4 [16], B4 [2],

B5 [6], C1 [7], C2 [8], A3 [15], C5 [11], C3 [9], A1 [5], and B2 [13]. The last cluster comprised accessions C4 [10] and D1 [3]. The study found that accessions D3 [18], D4 [19], and B3 [1] were consistently different from other accessions based on their morphological characters and physical environmental conditions. The leaf surface index of these accessions was relatively higher than that of other accessions. The clustering system involved many factors, and even if one variable showed no difference between accessions, multifactor considerations could still show different clustering results. The greater the Euclidean distance, the greater the similarity between accessions in influencing factors. The clustering system considered the distance between two variables by considering the relationship between angle and distance, similar to the Pythagorean principle (33-35).

### Conclusion

The study of Liberica coffee plantations in Banyuwangi revealed that environmental factors, such as light intensity and relative humidity, significantly impacted the plants' morphological variation, including leaf shape index, number of flowers per inflorescence, and leaf surface index. Unstable weather can also influence environmental factors, temporarily affecting morphological traits. A statistical analysis found that only two variables significantly correlated throughout the data set. Specifically, light intensity and the number of flowers per inflorescence were the only factors that exhibited a noteworthy correlation.

### Acknowledgements

This research was supported by the Ministry of Education, Culture, Research, and Technology of the Republic of Indonesia through Program Magister Menuju Doktor Untuk Sarjana Unggul (PMDSU) Batch VI. We Thank Riyan Riyadlun

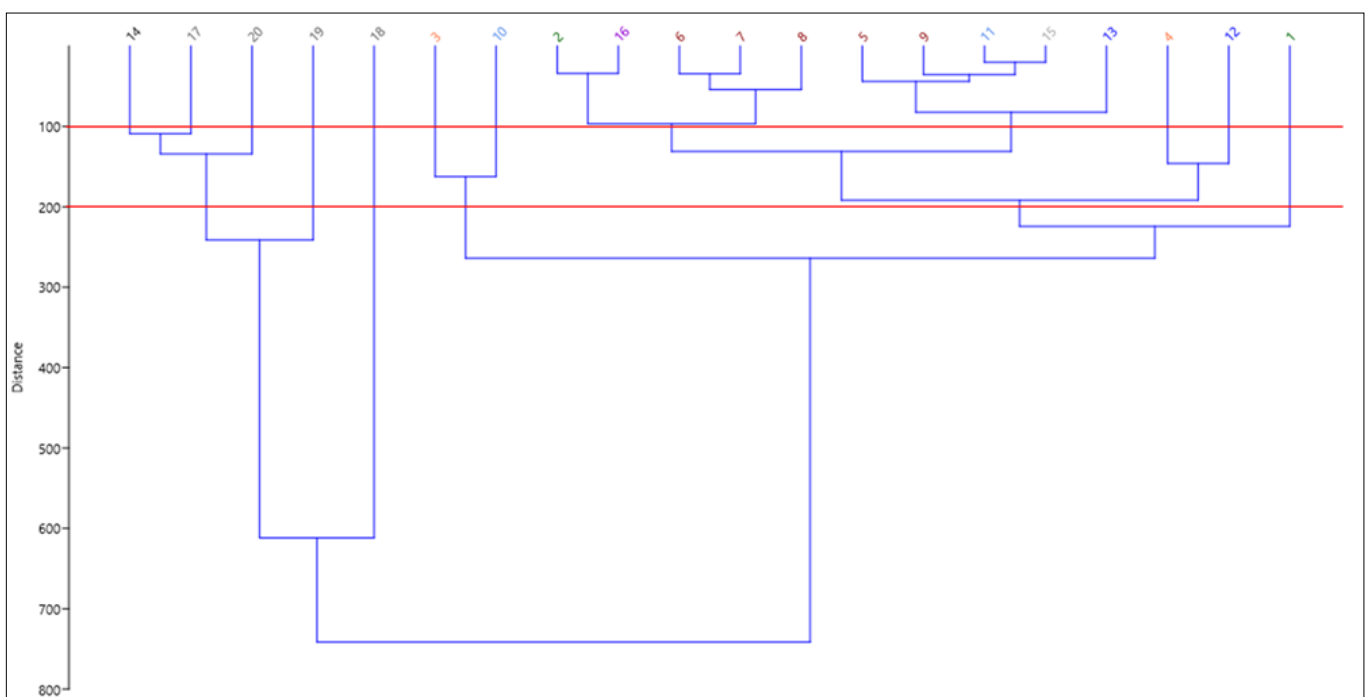

**Fig. 8.** Liberica coffee clustering based on morphological trait and environmental factors using Euclidean distance (1-2 Bulusari 1; 2-4 Bulusari 2; 5-9 Gombengsari 1; 10-11 Gombengsari 2; 12-13 Gombengsari 3; 14 Papring 2; 15 Papring 1; 16 Secang, 17-20 Telemung).



Najih, Titanio Auditya Pribadi, and Laila Nur Habibah for their technical support during data collection. Additionally, we would like to thank Jehan Ramdani Hariyati for providing insightful feedback throughout the research process.

### Authors' contributions

NIM designed the study conception and framework, performed the experimental research, data analysis, and interpretation, and drafted the manuscript. RA encouraged the first author to conceive the presented idea and supervised the project. LH contributed to the research design and supervised the findings of this work. All authors read and approved the final manuscript.

### Compliance with ethical standards

**Conflict of interest:** Authors do not have any conflict of interests to declare.

**Ethical issues:** None.

### References

- N'Diaye A, Poncet V, Louarn J, Hamon S, Noirot M. Genetic differentiation between *Coffea liberica* var. *liberica* and *C. liberica* var. *dewevrei* and comparison with *C. canephora*. *Plant Syst Evol.* 2005;253:95-104. <https://doi.org/10.1007/s00606-005-0300-1>
- N'Diaye A, Noirot M, Serge H, Poncet V. Genetic basis of species differentiation between *Coffea liberica* Hiern and *C. canephora* Pierre: Analysis of an interspecific cross. *Genet Resour Crop Evol.* 2007;54(5):1011-21. <https://doi.org/10.1007/s10722-006-9195-0>
- Hakim L. *Agroforestri Kopi: Mendorong Tanaman Hayati dan Wisata Kopi* [E-book]. Malang: Media Nusa Creative. 2021 [cited 1 August 2023]; p. 29-41. Available from: <https://ppsub.ub.ac.id/JurnalPPSUB/JITODE/LH/E-book%20Agroforestri%20Kopi%20taman%20kehati%20dan%20wisata%20kopi%20%20Luchman%20Hakim.pdf>
- Prasetyo P, Hidayat R, Nyoto, Purnomo H. *Budidaya Kopi Liberika di Lahan Gambut*. Center for International Forestry Research (CIFOR); 2019. [cited 20 August 2023]. Available from: [https://www.cifor.org/publications/pdf\\_files/flyer/7330-Flyer.pdf](https://www.cifor.org/publications/pdf_files/flyer/7330-Flyer.pdf)
- Hafif B, Sasmita KD. The organic carbon dynamics of peat soil under liberica coffee cultivation. *IOP Conference Series: Earth and Environmental Science.* 2020;418(1):1-7. <https://doi.org/10.1088/1755-1315/418/1/012021>
- Baltazar AMP, Buot IE. Short communication: Leaf architectural analysis of taxonomic confusing coffee species: *Coffea liberica* and *Coffea liberica* var. *dewevrei*. *Biodiversitas.* 2019;20(6):1560-67. <https://doi.org/10.13057/biodiv/d200611>
- Farony DI, Sunarharum WB, Hakim L. Promoting geographical indication of Banyuwangi liberoid coffee: A community capital framework. *Jurnal Presipitasi.* 2023;20(1):402-16. <https://doi.org/10.14710/presipitasi.v20i2.402-416>
- Hariyati JR, Siswanto D, Arisoesilaningsih E, Hakim L. Diversity and estimated above ground biomass of shade trees in some coffee-based agroforestries, Banyuwangi regency. *Advances in Biological Sciences Research; 7th International Conference on Biological Science (ICBS 2021).* 2022;Volume 22:ISBN: 10.2991/absr.k.220406.086. <https://doi.org/10.2991/absr.k.220406.086>
- IPGRI. Descriptors for coffee (*Coffea* spp. and *Psilanthus* spp.). In *International Plant Genetic Resources Institute* [Internet]; 1996. Available from: <https://www.biodiversityinternational.org/e-library/publications/detail/descriptors-for-coffee-coffee-spp-and-psilanthus-spp/>
- Huang GH. Measure of association. *International Encyclopedia of Education.* 2010;260-63. <https://doi.org/10.1016/b978-0-08-044894-7.01342-7>
- Nair PKR. Classification of agroforestry systems. *Agrofor Syst.* 1985;3:97-128. <https://doi.org/10.1007/BF00122638>
- Kumar P, Singh RP, Singh AK, Kumar V. Quantification and distribution of agroforestry systems and practices at global level. *HortFlora Research Spectrum.* 2014;3(1):1-6.
- Triwanto J, Arrofi FGZ, Rahayu EM. Contribution of coffee agroforestry to the income of farmers in Tulungrejo village, Ngantang district, Malang regency. *Jurnal Penelitian Kehutanan Wallacea.* 2022;11(2):79-88. <http://dx.doi.org/10.18330/jwallacea.2022.vol11i2ss2pp79-88>
- Hakim L, Rahardi B, Guntoro DA, Mukhoyaroh NI. Coffee landscape of Banyuwangi geopark: Ecology, conservation and sustainable tourism development. *Journal of Tropical Life Science.* 2021;12(1):107-16. <https://doi.org/10.11594/JTLS.12.01.11>
- Liebig T, Ribeyre F, Läderach P, Poehling H, van Asten P, Avelino J. Interactive effects of altitude, microclimate and shading system on coffee leaf rust. *Journal of Plant Interactions.* 2019;14(1):407-15. <https://doi.org/10.1080/17429145.2019.1643934>
- Supriadi H. *Persiapan dan kesesuaian lahan tanaman kopi: Kesesuaian lahan* [Internet]; 2017. [cited 1 Desember 2022]. Available from: <http://balittri.litbang.pertanian.go.id/index.php/berita/info-teknologi/474-persiapan-dan-kesesuaian-lahan-tanaman-kopi?start=1>
- Arisandi DP, Munandar DE, Slameto. Respon karakteristik fisiologi dan pertumbuhan bibit kopi robusta (*Coffea canephora*) klon BP 358 dan BP 308 pada berbagai tingkat naungan. *Berkala Ilmiah Pertanian.* 2015;1(1):1-5.
- Baligar VC, Elson MK, He Z, Li Y, Paiva AdQ, Almeida AAF, Ahnert D. Light intensity effects on the growth, physiological and nutritional parameters of tropical perennial legume cover crops. *Agronomy.* 2020;10(10):1515. <https://doi.org/10.3390/agronomy10101515>
- Dincer I, Rosen MA. Chapter 6 - Exergy analyses of psychrometric processes. *Exergy (Third Edition).* Elsevier. 2021;101-23. <https://doi.org/10.1016/B978-0-12-824372-5.00006-3>
- Zebende GF, Brito AA, Silva Filho AM, Castro AP. pDCCA applied between air temperature and relative humidity: An hour/hour view. *Physica A: Statistical Mechanics and its Applications.* 2018;49:17-26. <https://doi.org/10.1016/j.physa.2017.12.023>
- Suzuki M, Umeda H, Matsuo S, Kawasaki Y, Ahn D, Hamamoto H, Iwasaki Y. Effects of relative humidity and nutrient supply on growth and nutrient uptake in greenhouse tomato production. *Sci Hort.* 2015;187:44-49. <https://doi.org/10.1016/j.scienta.2015.02.035>
- Erwiyono R, Yacob RY, Usmedi. Pengaruh pola curah hujan terhadap produksi kopi: Studi di satu perkebunan di banyuwangi. *Jurnal Agrotropika.* 2009;14(1):29-36.
- Chabot BF, Chabot JF. Effects of light and temperature on leaf anatomy and photosynthesis in *Fragaria vesca*. *Oecologia.* 1977;26(4):363-77. <https://doi.org/10.1007/BF00345535>. PMID: 28309501
- Wu Y, Gong W, Yang W. Shade inhibits leaf size by controlling cell proliferation and enlargement in soybean. *Sci Rep.* 2017;7(1):9259. <https://doi.org/10.1038/s41598-017-10026-5>

25. Dinh TLA, Aires F, Rahn E. Statistical analysis of the weather impact on robusta coffee yield in Vietnam. *Front Environ Sci.* 2022;10:820916. <https://doi.org/10.3389/fenvs.2022.820916>
26. Lever J, Krzywinski M, Altman N. Principal component analysis. *Nat Methods.* 2017;14:641-42. <https://doi.org/10.1038/nmeth.4346>
27. Jolliffe IT, Cadima J. Principal component analysis: A review and recent developments. *Phil Trans R Soc A.* 2016;374:20150202. <http://doi.org/10.1098/rsta.2015.0202>
28. Tsoufidis L, Athanasiadis I. A new method of identifying key industries: A principal component analysis. *Economic Structures.* 2022;11(2):1-23. <https://doi.org/10.1186/s40008-022-00261-z>
29. Martono, Galih Hendro, Adji TB, Setiawan NA. Penggunaan metodologi analisa komponen utama (PCA) untuk mereduksi faktor-faktor yang mempengaruhi penyakit jantung koroner. *Seminar Nasional Science, Engineering and Technology.* 2012;47:1-5.
30. Purnama DI, Sihombing PR. Perbandingan analisis komponen utama dan robust PCA (ROBPCA) (Studi kasus: Pada analisis data rata-rata pengeluaran per kapita sebulan untuk komoditas makanan di provinsi sulawesi selatan). *Jurnal Bayesian: Jurnal Ilmiah Statistika dan Ekonometrika.* 2021;1(1):67-76.
31. Murugan M, Alagupalamuthirsolai M, Ashokkumar K, Anandhi A, Ravi R, Rajangam J. Climate change scenarios, their impacts and implications on Indian cardamom-coffee hot spots; one of the two in the world. *Front Sustain Food Syst.* 2022;6:1057617. <https://doi.org/10.3389/fsufs.2022.1057617>
32. Raharjeng ARP. Pengaruh faktor abiotik terhadap hubungan kekerabatan *Sansevieria trifasciata* L. *Jurnal Biota.* 2015;1(1):33-41.
33. Elmore KL. Euclidean distance as a similarity metric for principal component analysis. *American Meteorological Society.* 2001;129:540-49. [https://doi.org/10.1175/1520-0493\(2001\)129%3C0540:EDAASM%3E2.0.CO;2](https://doi.org/10.1175/1520-0493(2001)129%3C0540:EDAASM%3E2.0.CO;2)
34. Miftahuddin Y, Umaroh S, Karim F. Perbandingan metode perhitungan jarak euclidean, haversine, dan manhattan dalam penentuan posisi karyawan (Studi Kasus: Institut Teknologi Nasional Bandung). *Jurnal Tekno Insentif.* 2020;14(2):69-77. <https://doi.org/10.36787/jti.v14i2.270>
35. Suwanda R, Syahputra Z, Zamzami EM. Analysis of euclidean distance and manhattan distance in the K-means algorithm for variations number of centroid K. *Journal of Physics Conference Series.* 2020;1566(1):012058. <https://doi.org/10.1088/1742-6596/1566/1/012058>