



PATENT ARTICLE

# A novel stereoscopic mode of planting and breeding shed

Yanbin Hua<sup>1#</sup>, Pei Ying Ong<sup>2#</sup>, Chi Nhan Tran<sup>3</sup>, Chew Tin Lee<sup>2\*</sup> and Ken Nagasaka<sup>4\*</sup>

<sup>1</sup>Farmland Protection and Ecological Station, Jiexiu Bureau of Agriculture and Rural Affairs, Jiexiu 032 000, Shanxi, China

<sup>2</sup>Faculty of Chemical and Energy Engineering, Universiti Teknologi Malaysia, 81310 Johor Bahru, Johor, Malaysia

<sup>3</sup>Post-harvest Technology Department, Institute of Food and Biotechnology, Can Tho University, Can Tho City 900 000, Vietnam

<sup>4</sup>Department of Electrical Engineering and Computer Science, Tokyo University of Agriculture and Technology, 2-24-16 Nakamachi, Koganei-shi, Tokyo 184-8588, Japan

#These authors contributed equally to this work.

\*Emails: [ctlee@utm.my](mailto:ctlee@utm.my) (CTL); [bahman@cc.tuat.ac.jp](mailto:bahman@cc.tuat.ac.jp) (KN)



## ARTICLE HISTORY

Received: 29 November 2024

Accepted: 21 December 2024

Available online

Version 1.0 : 25 December 2024



## Additional information

**Peer review:** Publisher thanks Sectional Editor and the other anonymous reviewers for their contribution to the peer review of this work.

**Reprints & permissions information** is available at [https://horizonepublishing.com/journals/index.php/PST/open\\_access\\_policy](https://horizonepublishing.com/journals/index.php/PST/open_access_policy)

**Publisher's Note:** Horizon e-Publishing Group remains neutral with regard to jurisdictional claims in published maps and institutional affiliations.

**Indexing:** Plant Science Today, published by Horizon e-Publishing Group, is covered by Scopus, Web of Science, BIOSIS Previews, Clarivate Analytics, NAAS, UGC Care, etc See [https://horizonepublishing.com/journals/index.php/PST/indexing\\_abstracting](https://horizonepublishing.com/journals/index.php/PST/indexing_abstracting)

**Copyright:** © The Author(s). This is an open-access article distributed under the terms of the Creative Commons Attribution License, which permits unrestricted use, distribution and reproduction in any medium, provided the original author and source are credited (<https://creativecommons.org/licenses/by/4.0/>)

## CITE THIS ARTICLE

Hua Y, Ong PY, Tran CN, Lee CT, Nagasaka K. A novel stereoscopic mode of planting and breeding shed. Plant Science Today (Early Access). <https://doi.org/10.14719/pst.6419>

## Abstract

A novel stereoscopic mode of planting and breeding shed has been designed. The shed body comprises of a steel frame structure inserted with four transverse beams along the length direction of the shed through the middle part of the shed body. The transverse beams are covered with a partition. The top of the shed body is covered with 300 and 80 solar panels, while the lower and upper sides are covered with the first and second transparent materials. The partition is provided with 200 and 40 breeding cages, where the 200 and 40 manure drains connected to the breeding cages (each manure drain connected to one breeding cage) are vertically arranged under the partition. The two manure collection pipes are connected to the manure drains at a slope of 60°. The transverse beams have 80 adjustable hammocks, which serve as space-saving hanging pots to grow plants. The lower side of the partition is provided with eighty spray heads through the pipes. The inner side of the shed body is provided with twenty heating devices. The novel planting and breeding shed can effectively utilize space, achieving the recycling of resources and waste, maximizing economic benefits and realizing the concept of low-carbon and green environmental protection.

## Keywords

Combined planting and breeding; multi-layered structure; space-saving; manure recycling; solar panel

## Introduction

The total land resources are abundant but poor per capita in China (1). As the population continues to increase and the industrialization process has accelerated, industrial land has continued to expand and the consumption of land resources has been further increased (2, 3). While the total population continues to increase, China's per capita arable land and breeding area have fallen rapidly (4, 5). With the gradual rise in the demand for planting and breeding, separate planting and breeding venues could cause a waste of resources, and the applicability and practicality are restricted (6). Therefore, a novel stereoscopic mode of combined planting and breeding shed is proposed to solve the current deficiencies.

## The design and advantages of the novel stereoscopic mode of planting and breeding shed

Stereoscopic refers to a process by which two photographs of the same object taken at slightly different angles are viewed together, creating an impression of 3D effect and solidity. The stereoscopic mode refers to a multi-layered structure shed comprised of the top, middle and bottom layers. The design aims to realize multiple agricultural species production that promotes resource recycling in an efficient and environmentally friendly way. The design aims to enhance the utilization rate of land and resources and promote the virtuous cycle of the ecosystem. A novel stereoscopic mode of planting and breeding shed is designed in this study. The design includes a shed body made of a steel frame structure, with 4 transverse beams set along the length direction of the shed body through the middle of the shed body. The transverse beams are covered with a partition, and their lower and upper outer sides are covered by transparent polyethylene (PE) sheets with a thickness of 0.7 mm and 1 m in length. The top of the shed body is covered with 300 and 80 solar panels. The partition has 200 and 40 breeding cages where the 200 and 40 manure drains connected to the breeding cages (each manure drain connected to one breeding cage) are vertically arranged under the partition. The shed body is provided with two manure collection pipes connected to the manure drains at a slope of 60°. The transverse beams are provided with 80 adjustable hammocks, which serve as space-saving hanging pots to grow plants, whereas the lower side of the partition is provided with 80 spray heads through the pipes. The inner side of the shed body is provided with 20 heating devices.

The advantages of the novel stereoscopic mode of planting and breeding shed compared with the existing technologies are as follows:

1. The shed body is based on a 3 layer structure: (i) The top layer is laid with solar panels to realize the use of power and power transmission for the grid; (ii) the bottom layer is a planting bed to grow fruits, vegetables and flowers; (iii) the middle layer serves as the breeding cages for poultry breeding. The poultry manure will drop to the bottom layer for compost treatment, where the compost can be used to fertilize the planting bed with fruits and vegetables.
2. The adjustable hammock set on the bottom partition of the shed body can maximize the planting area where its height is adjustable. It is convenient for farmers to plant and pick the fruits and vegetables located on the ground. The rotten fruits and vegetables can be used as feed for poultry breeding.
3. The novel planting and breeding shed is designed to effectively utilize space, achieving the recycling of resources, maximizing economic benefits, and realizing the concept of low carbon via renewable energy (solar) and resource recycling. As shown in Figs. 1-3, a novel stereoscopic mode of planting and breeding shed includes the shed body (①) located on the ground used for planting, with a length of 133 m, a width of 5 m and a height of 6 m. The steel frame structure of the shed body (①) is connected to the ground through a concrete base to ensure the structural stability of the shed body (①).

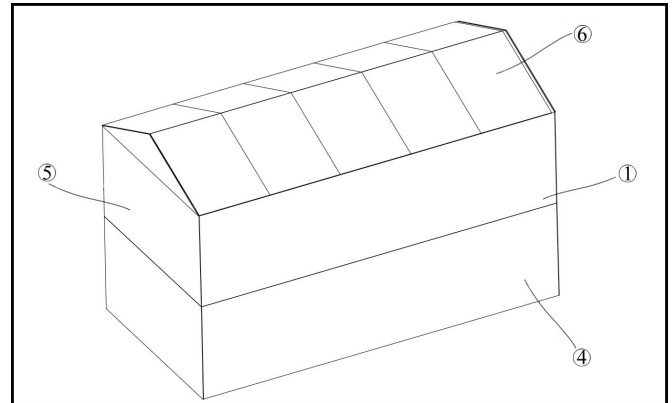

**Fig. 1.** The structural schematic diagram of the novel stereoscopic mode of the planting and breeding shed (① Shed body; ④ The first transparent material; ⑤ The second transparent material; ⑥ Solar plate).

The shed body (①) has 4 longitudinally arranged transverse beams (②) in its interior middle, and the transverse beams (②) are covered with a partition (③), which is supported by transverse beams (②) which divides the shed body (①) into two regions. The lower part of the shed body (①) is the planting area for fruits and vegetables. The sales of the excess fruits and vegetables and the withered leaves are used as poultry feed, realizing resource recycling. The upper part of the shed body (①) is an area for poultry breeding. The first transparent material (④) surrounds the shed body (①), covering the outside lower part of the partition (③). The first transparent material (④) is a transparent PE plastic sheet, which can ensure the photosynthesis of fruits and vegetables. The shed body (①) is surrounded by the second transparent material (⑤), which is a transparent PE plastic sheet covering the outside upper part of the partition (③). The second transparent material (⑤), like the first one, is a lightweight, transparent insulating material that provides a comfortable temperature for poultry while ensuring a good lighting effect. The shed body (①) is covered with 300 and 80 solar panels (⑥) at the top layer, and lightweight colored steel plates are used on top of the shed body (①). The shed body (①) has a slope of 30-35°. Most Chinese cities are in the mid-latitude area and few are in the low-latitude area. The best tilt angle in the low- and mid-latitude areas is 20-25° and 30-35° respectively, where solar panels can achieve the highest energy efficiency. Solar panels (⑥) are installed on lightweight colored steel plates. The power generation components used for solar panels (⑥) are installed on the shed body (①). The electricity generated by solar panels (⑥) can fulfil the daily electricity needs of the plants and poultry in the shed body (①). The electricity in excess can be sold and transmitted to the grid. There are 200 and 40 breeding cages (⑦) on the partition (③), set up axially along the length of the shed (①). The breeding cages (⑦) can breed various poultry. There are 200 and 40 manure drains (⑧) connected to the breeding cages (⑦) (each manure drain connected to one breeding cage) set vertically in the lower partition (③). The poultry manure in the breeding cages (⑦)

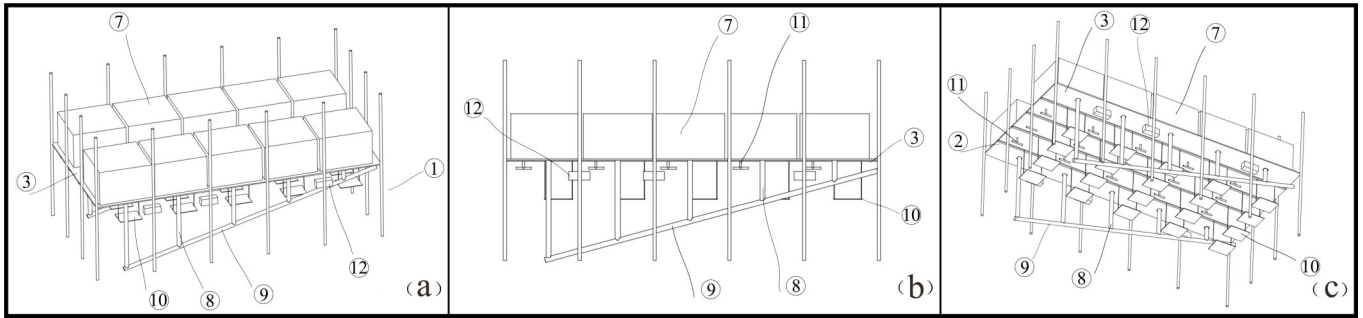

**Fig. 2.** The schematic diagram of the internal structure of the novel stereoscopic mode of the planting and breeding shed (① Shed body; ② Transverse beam; ③ Partition; ⑦ Breeding cage; ⑧ Manure drain; ⑨ Manure collection pipe; ⑩ Adjustable hammock; ⑪ Spray head; ⑫ Heating device). (a)-(c): the internal structure in different angles.

can be removed through the manure drains (⑧) to ease the cleaning process of the cages (⑦). Two manure collection pipes (⑨) are connected to the manure drains (⑧) in the shed body (①) and the manure in the breeding cages (⑦) is transferred to the manure collection pipes (⑨) through the manure drains (⑧). Manure collection pipes (⑨) are installed with a slope to ensure that the manure in manure collection pipes (⑨) can be readily collected and used as fertilizers at the bottom layer of the planting beds. The manure collection pipes (⑨) are connected to the water source with the pipes at the top of the upper part, which can readily flush the manure collection pipes (⑨) for cleaning. There are 2 manure collection grooves on the bottom surface where the lower end of the manure collection pipes (⑨) extends to the manure collection grooves. The manures are collected in the breeding cages (⑦) through the manure drains (⑧) and manure collection pipes (⑨). It is a convenient design for treating the manures in the manure collection grooves and for the fertilization of fruits and vegetables. Eighty adjustable hammocks (⑩) are installed on the four transverse beams (②). The adjustable hammocks (⑩) can be used to place flowerpots and plant flowers. The adjustable hammock (⑩) includes the bed body (⑬), steel wire rope (⑭), the first fixed pulley (⑮) and the second fixed pulley (⑯). There is a first fixed wheel (⑮) at both ends of the bed body (⑬) on the transverse beam (②). The second fixed pulley (⑯) is set at the four corners of the

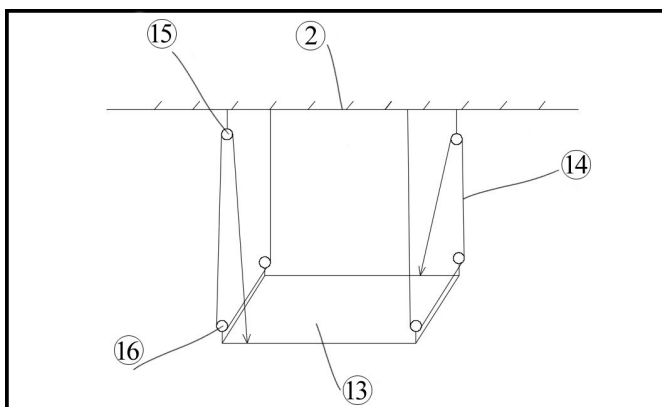

**Fig. 3.** The structural schematic diagram of the adjustable hammock of the novel stereoscopic mode of the planting and breeding shed (② Transverse beam; ⑬ Bed body; ⑭ Steel wire rope; ⑮ The first fixed pulley; ⑯ The second fixed pulley).

bed body (⑬), where one end of the two steel wire ropes (⑭) is connected to the transverse beam (②) respectively, and another end of the second fixed pulley (⑯) is fixed at the end of the bed body (⑬). The corresponding first fixed pulley (⑮) is connected to the bed body (⑬) activity. By pulling the free end of the steel wire rope (⑭) connected to the bed body (⑬) activity, one can adjust the height of the adjustable hammocks (⑩), where the distance to the ground can be set. The design can help the farmers plant and pick the fruits and vegetables at the bottom of the shed. Eighty spray heads (⑪) are created through the pipes at the bottom of the partition (③). The height of the spray heads (⑪) is higher than that of the adjustable hammocks (⑩). The spray heads (⑪) can spray water on fruits, vegetables and flowers. There are 20 heating devices (⑫) installed inside the shed body (①), where the heating devices (⑫) are installed axially along the middle part of the shed body (①). The heating devices (⑫) can be adjusted to the temperature of the shed body (①) to optimize the condition for growing fruits, vegetables and flowers.

### Current and future developments

A novel stereoscopic mode of planting and breeding shed is designed with a multi-layered structure shed comprised of the top, middle and bottom layers aiming to realize multiple agricultural species production that promotes resource recycling in an efficient and environmentally friendly way and enhances the utilization rate of land and resources and promote the virtuous cycle of the ecosystem. Future work on the cost-benefit analysis is needed to understand and study the economic benefits of this new mode of planting and breeding shed at a commercial level.

### Intellectual property

A novel stereoscopic mode of planting and breeding shed has been granted a Chinese Utility Mode Patent (ZL 2024 2 0361671.X; Publication number: CN 222128845 U).

## Acknowledgements

The authors thank the China National Intellectual Property Administration for the patent examination and grant of a Chinese Utility Mode Patent on a novel stereoscopic mode of planting and breeding shed.

## Authors' contributions

YH, CTL and KN carried out the patent design and application of this work; YBH, PYO and CTL carried out the manuscript's original draft preparation, review and editing; CNT participated in the manuscript review and editing; CTL and KN carried out the manuscript supervision, review and editing. All authors read and approved the final manuscript.

## Compliance with ethical standards

**Conflict of interest:** The authors declare no conflict of interest.

**Ethical issues:** None

## References

1. Cai BM, Hubacek K, Feng KS, Zhang W, Wang F, Liu Y. Tension of agricultural land and water use in China's trade: teleconnections, hidden drivers and potential solutions. *Environmental Science and Technology*. 2020;54(9):5365-75. <https://doi.org/10.1021/acs.est.0c00256>
2. Mahtta R, Fragkias M, Güneralp B, Mahendra A, Reba M, Wentz EA, Seto KC. Urban land expansion: the role of population and economic growth for 300+ cities. *npj Urban Sustainability*. 2022;2(5):1-11. <https://doi.org/10.1038/s42949-022-00048-y>
3. Humbal A, Chaudhary N, Pathak B. Urbanization trends, climate change and environmental sustainability. In: Pathak B, Dubey RS (eds) *Climate Change and Urban Environment Sustainability. Disaster Resilience and Green Growth*. Springer, Singapore; 2023.151-66. [https://doi.org/10.1007/978-981-19-7618-6\\_9](https://doi.org/10.1007/978-981-19-7618-6_9)
4. Yang SQ, Li DL, Liao HP, Zhu L, Zhou MM, Cai ZC. Analysis of the balance between supply and demand of arable land in China based on food security. *Sustainability*. 2023;15(7):5706. <https://doi.org/10.3390/su15075706>
5. Liu CY, Song CQ, Ye SJ, Cheng F, Zhang LN, Li C. Estimate provincial-level effectiveness of the arable land requisition-compensation balance policy in mainland China in the last 20 years. *Land Use Policy*. 2023;131:106733. <https://doi.org/10.1016/j.landusepol.2023.106733>
6. Li HN, Wang XY, Zhao DL. Does the agricultural co-agglomeration help reduce livestock and poultry pollution? From the perspective of planting and breeding combination in China. *Heliyon*. 2023;9(7):e17821. <https://doi.org/10.1016/j.heliyon.2023.e17821>